

Cirval

Medium-low pressure gas regulator

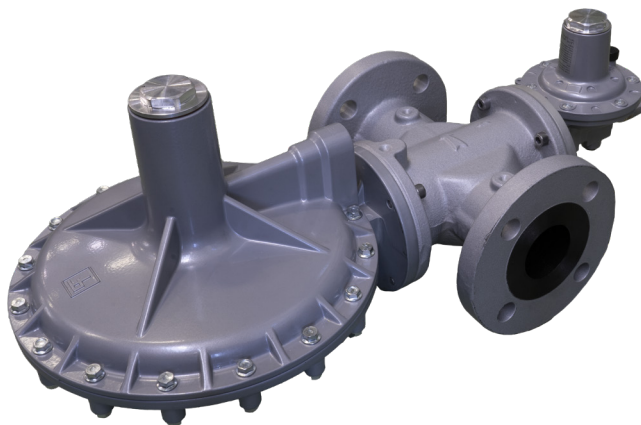

QUICK START GUIDE

- ENG** *Safety, installation and commissioning procedures.
More information and languages on page 8.*
- ITA** *Procedura di sicurezza, installazione, messa in servizio.
Ulteriori informazioni e lingue a pagina 8.*
- FRA** *Procédures de sécurité, d'installation et de mise en service.
Plus d'informations et de langues à la page 8.*
- DEU** *Sicherheits, Installations und Inbetriebnahmeverfahren.
Weitere Informationen und Sprachen auf Seite 8.*
- ESP** *Procedimientos de seguridad, instalación y puesta en servicio.
Más información e idiomas en la página 8.*
- RUS** *Процедуры безопасности, монтажа и ввода в
эксплуатацию.
Дополнительная информация и языки на странице 8.*
- CHN** *安全程序、安装和调试。
更多信息和语言，请参见第8页。*

SYMBOLS USED AND PERSONAL PROTECTIVE EQUIPMENT

				
Obligation to use safety or insulated gloves.	Obligation to use safety shoes.	Obligation to wear protective clothing.	Obligation to use a protective helmet.	Obligation to consult the quick start guide.
				
Obligation to use safety goggles.	Obligation to use noise protection equipment.	Obligation to use a protective mask.	Obligation to wear high visibility vests.	Symbol used to identify information of particular importance.

SAFETY REQUIREMENTS



The quick start guide does not substitute the use, maintenance and warning manual. It is mandatory to consult the manual on Pietro Fiorentini website



www.fiorentini.com



WARNING!

Failure to follow these instructions or to properly install and maintain the equipment may result in fire, explosion, property damage, serious injury, or death.

The equipment must be installed, operated, and maintained in compliance with all applicable local codes, regulations, and the instructions of the equipment's manual. If gas leakage or venting occurs, the equipment may require servicing. Failure to address this issue may create hazardous conditions. Contact a qualified gas service professional immediately.



WARNING!

Personal injury or equipment damage due to the bursting of pressure-containing components may occur if the equipment is overpressured or installed in conditions exceeding its specified limits.

Always refer to the manual and the nameplate for the equipment's operating limits. Additionally, ensure that adjacent piping and connections do not exceed their rated capacities. To prevent such risks, install appropriate pressure-relief or pressure-limiting devices to keep operating conditions within safe limits. Ensure compliance with all applicable local codes and regulations.



WARNING!

- Before proceeding with installation, make sure that the upstream and downstream valves installed on the line are shut off.
- To safely use the equipment, please observe the data on the attached nameplate.
- The installation of the equipment must be carried out by authorised, trained personnel who are familiar with the PPE to be used.
- For any further detail or information regarding the procedures, please refer to the use, maintenance and warning manual.

AFTER THE COMMISSIONING



WARNING!

- Check the sealing of upstream and downstream shut-off valve with a foaming substance.
- Check the pressure referring to the pressure gauge located upstream and downstream.
- Should any malfunction occur, please refer to the chapter 'Troubleshooting' of the manual to solve the issue, or contact Pietro Fiorentini.

INSTALLATION PROCEDURE FOR REGULATOR

1. Place the equipment in the section of the line.
2. Place the gaskets between the line flanges and the regulator flanges.
3. Insert the bolts into the appropriate holes of the connecting flanges.
4. Screw the bolts following the rules for tightening flanges.

CONNECTING THE SENSING LINES TO THE DOWNSTREAM PIPELINE

To obtain a good regulation it is essential that:

- the downstream shut-off valve is placed at least 6 times the nominal diameter of the tube downstream of the regulator;
- if there are external downstream sensing lines, check that they are placed on a straight section of pipe (of uniform diameter) with a length equal to at least 4 times the nominal diameter of the pipe itself.

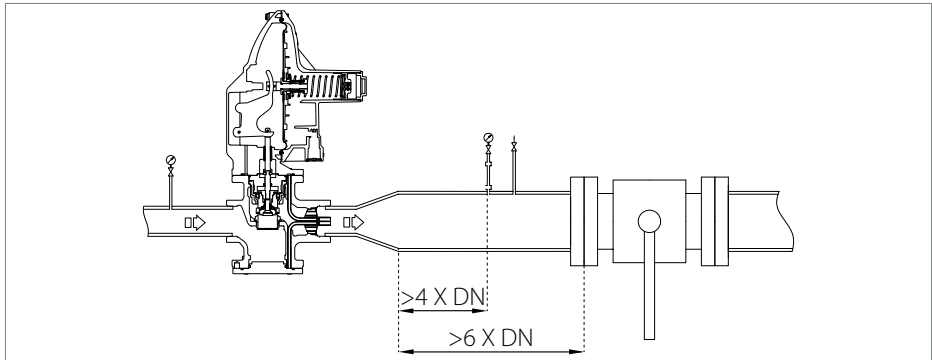

To avoid the collection of impurities and condensation in the pneumatic connections of the sensing lines it is necessary that:

- the connections of the pneumatic connection are always welded to the top or horizontal axis of the pipe itself;
- the hole on the pipe has no burrs or internal protrusions;
- the slope of the pneumatic connection is always 5-10% towards the connection of the downstream pipe.

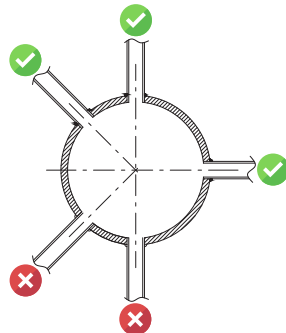

COMMISSIONING PROCEDURE FOR REGULATOR

PPE required:

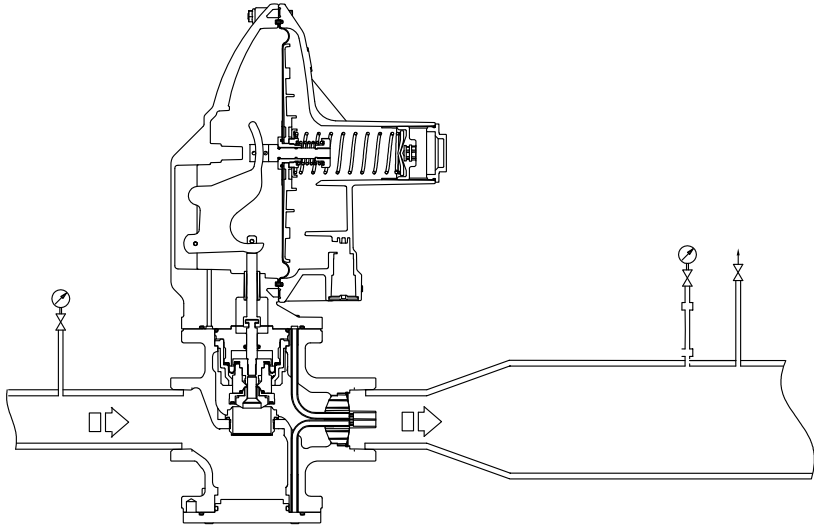

REGULATOR

1. Partially open the bleed cock.
2. Very slowly open the upstream shut-off valve.
3. Check the pressure of the line inlet pipe by referring to the upstream pressure gauge.
4. To calibrate the regulator to the required calibration value, turn the calibration ring nut:
 - clockwise to increase the pressure value;
 - counterclockwise to decrease the pressure value.
5. Place and secure the end cap.
6. Close the bleed cock.
7. Check that the downstream pressure (P_d), after an increment phase, does not exceed the closing pressure value.
8. Check with a foaming substance the tightness of all joints located between the shut-off valves.
9. Very slowly open the downstream shut-off valve until the pipeline is completely flooded.

COMMISSIONING PROCEDURE OF CIRVAL REGULATOR + CIRVAL REGULATOR IN-LINE MONITOR FUNCTION

PPE required:

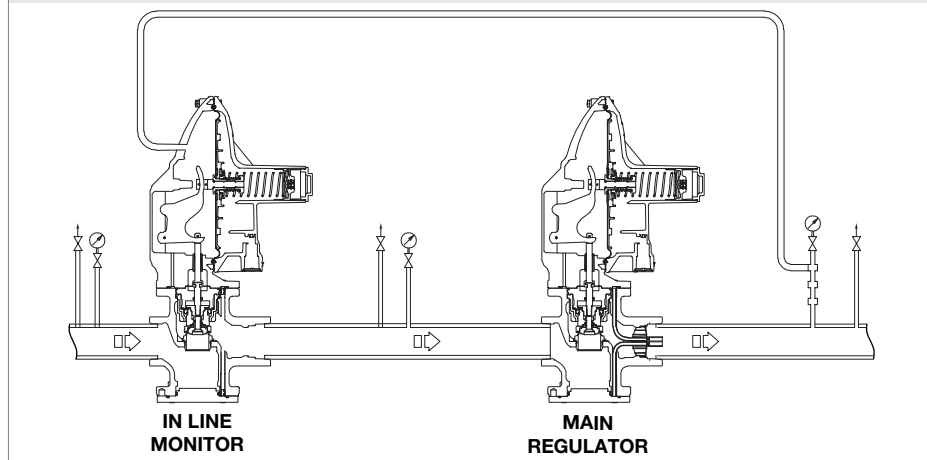

1. Remove the cap from the main regulator.
2. Remove the cap from the regulator in in-line monitor function.
3. Partially open the bleed cock.
4. Very slowly open the upstream shut-off valve, checking that the downstream pressure (Pd) indicated by the downstream pressure gauge does not exceed the required setting value by more than 50%.
5. Check the pressure of the line inlet pipe by referring to the upstream pressure gauge.
6. Increase the downstream pressure value (Pd) beyond the calibration pressure of the regulator with monitor function, by turning the adjustment ring nut of the main regulator clockwise.
7. To calibrate the regulator with in-line monitor function to the required calibration value, turn the calibration ring nut:
 - clockwise to increase the pressure value;
 - counterclockwise to decrease the pressure value.
8. Close the bleed cock.
9. Check that the downstream pressure (Pd), after an increment phase, does not exceed the closing pressure value.
10. Partially open the bleed cock.
11. Check that the calibration pressure of the main regulator is at the set value by referring to the pressure value indicated by the downstream pressure gauge.
12. Verify that the regulator with in-line monitor function is fully open (100%). The main regulator is fully open, when the pressure indicated on the intermediate pressure gauge is the same as the upstream pressure gauge.
13. Close the bleed cock and check that the downstream pressure (Pd), after an increment phase, does not exceed the closing pressure value.
14. Insert the plug into the main regulator then insert the plug into the regulator in monitor function.
15. Check with a foaming substance the tightness of all joints located between the shut-off valves. Slowly open downstream shut-off valve until the pipeline is completely flooded.

COMMISSIONING PROCEDURE OF THE CIRVAL REGULATOR + SLAM-SHUT VALVE LA

PPE required:

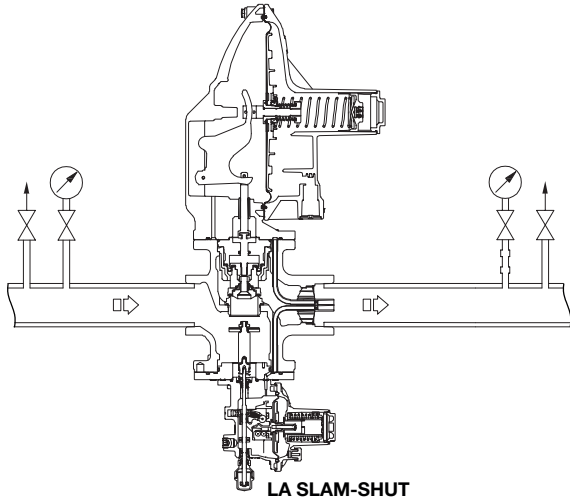

1. Check that the bleed cock is partially open.
2. Check that the LA slam-shut valve is in the closed position.
3. Partially open the upstream shut-off valve, checking the pressure value indicated by the upstream pressure gauge.
4. Perform the internal leakage test of the LA slam-shut valve.
5. Slowly pressurize the control line by turning the knob on the LA slam-shut valve, checking that the downstream pressure (P_d) indicated by the downstream pressure gauge does not exceed the required calibration value by more than 50%.
6. At the time the regulator goes into service, the pressure of the downstream pressure gauge will be equal to the setting value of the main regulator.
7. Fully open the upstream shut-off valve.
8. Check the pressure switch settings of the LA slam-shut valve (refer to section "Calibration procedure for LA slam-shut valve").
9. Check the calibration value of the regulator, act as below:
 - value of downstream pressure (P_d) less than the required calibration value: load the calibration spring by turning the adjustment ring nut clockwise;
 - value of downstream pressure (P_d) higher than the required calibration value: discharge the calibration spring by turning the adjustment ring nut counterclockwise.
10. Check the downstream pressure (P_d) by referring to the downstream pressure gauge.
11. Close the bleed cock.
12. Check that the downstream pressure (P_d), after an increment phase, does not exceed the closing pressure value.
13. Check with a foaming substance the tightness of all joints located between the shut-off valves.
14. Very slowly open the downstream shut-off valve until the pipeline is completely flooded.

CALIBRATION PROCEDURE FOR REGULATOR OR MONITOR IFM

PPE required:



Adjust the adjustment ring nut:

- anti-clockwise to decrease the adjusted pressure;
- clockwise to increase the adjusted pressure.

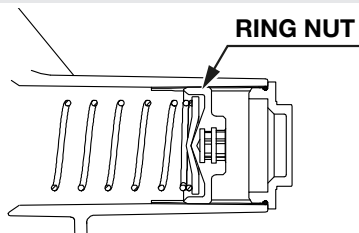

CALIBRATION PROCEDURE FOR LA SLAM-SHUT VALVE (LA-BP, LA-MP, LA-TR)

PPE required:

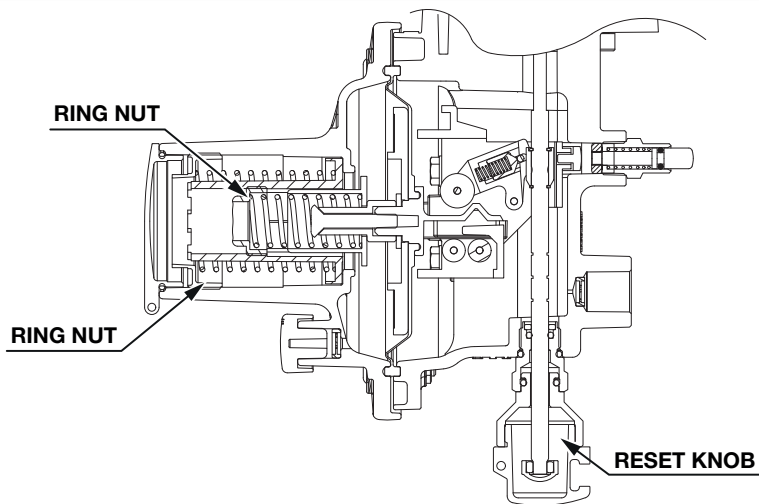

Adjust the maximum pressure ring nut:

- anti-clockwise to decrease the slam-shut device tripping pressure.
- clockwise to increase the slam-shut device tripping pressure.

Turn the minimum pressure ring nut:

- anti-clockwise to decrease the slam-shut device tripping pressure.
- clockwise to increase the slam-shut device tripping pressure.

In order to reset the slam-shut valve, move the reset knob that engages the control device of the mobile system. Open downstream shut-off valve very slowly until the pipeline fills completely.

Download | Scarica | Télécharger | Herunterladen | Descargar | Скачать | 下载

PFScan app



- ENG** Full access to all documentation, spring calibration tables, spare parts and complete manual. **INSTRUCTIONS:** 1. Scan the QR code to download the app 2. Open the app 3. Log in or register 4. Use the app to scan the QR code on the product
- ITA** Accesso completo a tutta la documentazione. Tabelle di calibrazione delle molle, parti di ricambio e manuale completo. **ISTRUZIONI:** 1. Scansiona il codice QR per scaricare l'app 2. Apri l'app 3. Accedi o registrati 4. Usa l'app per scansionare il codice QR sul prodotto.
- FRA** Accès complet à toute la documentation, aux tableaux d'étalonnage des ressorts, aux pièces de rechange et à la notice complète. **INSTRUCTIONS :** 1. Scanner le code QR pour télécharger l'application 2. Ouvrir l'application 3. Se connecter ou s'inscrire 4. Utiliser l'application pour scanner le code QR sur le produit.
- DEU** Vollständiger Zugriff auf alle Unterlagen, Federkalibrierungstabellen, Ersatzteile und das komplette Handbuch. **ANWEISUNGEN** 1. Scannen Sie den QR-Code, um die App 2 herunterzuladen. Öffnen Sie die App 3. Anmelden oder registrieren 4. Verwenden Sie die App, um den QR-Code auf dem Produkt zu scannen.
- ESP** Acceso completo a toda la documentación, tablas de calibración de muelles, piezas de repuesto y manual completo. **INSTRUCCIONES:** 1. Escanee el código QR para descargar la aplicación 2. Abra la aplicación 3. Acceda a la sesión o regístrese 4. Utilice la aplicación para escanear el código QR del producto.
- RUS** Полный доступ ко всей документации, таблицам калибровки пружин, запасным частям и полному руководству. **ИНСТРУКЦИИ:** 1. Отсканируйте QR-код, чтобы скачать приложение 2. Откройте приложение 3. Войдите или зарегистрируйтесь 4. Используйте приложение для сканирования QR-кода на товаре.
- CHN** 可全面访问所有文档、弹簧校准表、备件和完整手册。说明：1.扫描二维码下载应用程序 2.打开应用程序 3.登录或注册 4.使用应用程序扫描产品上的二维码。

PIETRO FIORENTINI U.S.A. | 606 Park Dr. Weirton, WV 26062

Tel. +1 (304) 232-9115 | www.fiorentini-usa.com | fiو.westvirginia@fiorentini.com

PIETRO FIORENTINI S.p.A. | Via Enrico Fermi, 8/10 36057 Arcugnano (VI) ITALY

Tel. +39 0444 968511 | www.fiorentini.com | sales@fiorentini.com

UG0182ENG - rev. B

The data are not binding. We reserve the right to make changes without prior notice.